



A.D. METALNA INDUSTRIJA VRANJE  
Radnička br:1

## SOLID FUEL STOVE

### ELITA

### ELITA II



*This product meets the requirements of the Ecodesign Directive in terms of efficiency and air pollution level, in order to contribute to the reduction of energy consumption and negative environmental impact.*

## INSTRUCTIONS FOR INSTALLATION AND USE

ENG\_v.2.0

1080061

## DEAR CUSTOMERS!

Thank you for the purchase of our product.

You have chosen a good quality and economical product, the result of our long-term experience in the production of cookers and pellet stoves.

Hopefully we have managed to meet your requests completely, both regarding design and the size of residential area to be heated.

Prior to the stove installation please read this manual and respect all instructions.

It is necessary to comply with the effective construction rules and regulations on firebox, as well as all required local, national and European standards.

### Important notes:

#### Never manipulate fireplace by holding cast top plate!

The fireplace should be manipulated only while it is packed. The packed stove should be brought to the location where it would be installed and only then it should be unpacked (figure 1). It should be moved by holding its lateral sides or by using ropes below the fireplace. Fireplace lifting should never be performed by holding its top cast iron plate because the sealing of top plate could be damaged which could compromise the performances of fireplace.

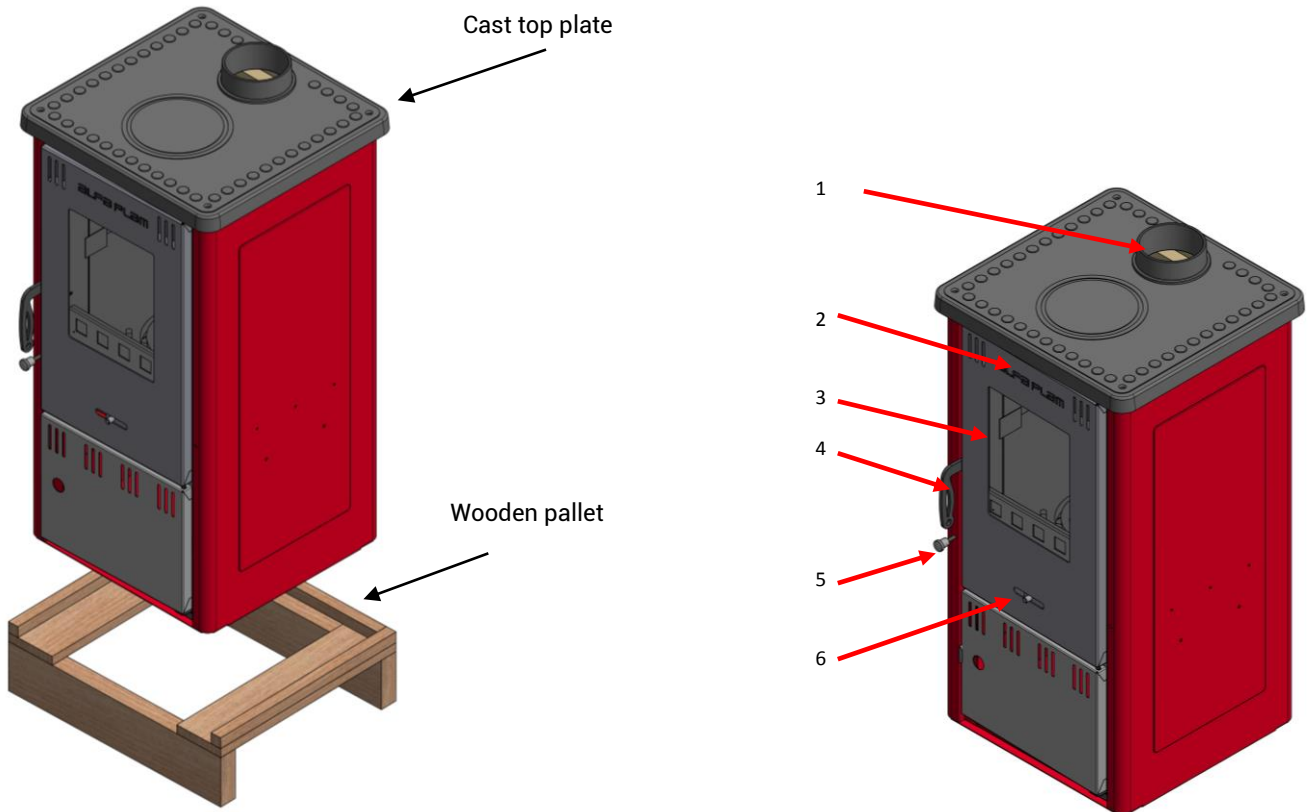

Figure 2. Solid Fuel Stove

1. Control of flue gas
2. Secondary air inlet
3. Combustion chamber door
4. Handle
5. Primary air regulator
6. Grate shaker

## CAUTION!



**SURFACES CAN BE VERY HOT!**  
BE VERY CAREFUL

For the proper stove operation you should read carefully this manual and follow the stated instructions.

During combustion, thermal energy is released, which significantly influences increasing temperatures of surfaces, doors, handles, glass and exhaust gases. Avoid contact with those elements if you are not wearing protective equipment (including a protective glove).

**Ensure that children are aware of the risks and keep them away from the stove during operation.**

Packaging components can be dangerous for children and adults with disabilities. There is a risk of injury. It is necessary to remove all components in a safe place.

Replacement parts, other than our tested original parts, must not be used on the stove. **Alfa Plam is not responsible for the consequences of upgrading the stove.**

The air inlet or flue gas outlets must not be reduced.

The area where the appliance is installed should have satisfactory fresh air supply. If the windows and doors are well sealed, or if other air-consuming appliances such as a steam cleaner, a tumble dryer, a fan, etc., are installed in the area where the stove is placed, and take air, in such circumstances, air for combustion (fresh air) should be led from outside.

**Use only recommended types of fuel – namely wood logs.**

The necessary discharge pressure should be 12 Pa during normal workload. If the pressure exceeds 15 Pa, throttle valve spacer should be used for the discharge pipe (Figure 8a, and 8b)

**The ashpan must not contain any flammable materials.** The filling level should not exceed the height of lateral sides to the ashpan.



**Caution!**

**The door and the section containing ash should always be closed (except in lighting fire, fuel supply and cleaning up ash) to prevent the escape of hot air.**

It is not allowed to do modifications on the stove, except with the use of recommended and inspected original parts and provided that the works are performed only by our service company.

In case fire breaks out in the chimney, the stove door should remain closed with the air control damper also being closed! **Never attempt to put out fire by pouring water down the chimney.** Due to water vapor created in the chimney there is a risk of explosion. In case of emergency call the fire department on their emergency helpline number!

In case of interference close all air control dampers and until the cause is eliminated do not inject new fuel into the stove!

If you follow the installation and operation instructions, the stove shall be a reliable heat source. All possible problems could be solved through our service company. In case of complaints including problems or functional errors, please contact our service company. They shall assist you in placing orders on spare parts.

Do not store flammable substances or wood under the ash box, do not store firewood in it.

## The content:

1. Technical data .....	1
2. Stove description.....	1
3. Air regulation.....	1
3.1. Primary air.....	1
3.2. Use of knobs on firebox door.....	1
4. Stove installation.....	2
5. Stove commissioning .....	3
5.1. Stove commissioning and stove operation .....	3
5.2. Stove maintenance and cleaning.....	3
6. General data .....	4
7. Frequently Asked Questions .....	4
8. The Nameplate .....	5

## 1. Technical data

- width.....	455 mm
- depth.....	471 mm
- height.....	905 mm
- nominal heat output.....	6,5 KW
- Efficiency degree (%).....	84,1 %
- diameter of flue pipe connection.....	Ø120 mm
- draught.....	12 Pa
- stove weight.....	67 kg
- flue engagement.....	upwards
- waste gas temperature – wood logs:.....	222 ° C
- CO (%) with split logs:.....	0,0951 %

## 2. Stove description

The stove is intended for occasional heating of closed rooms, with closed firebox doors. Made of sheet metal positions, with a grille, tertiary air guide and cast iron plate. The firebox is lined with replaceable fireclay boards. The outer coating is enameled or painted. The opening for adjusting the air needed for ignition and combustion is located on the firebox door. There are tertiary air openings on the back of the furnace.

## 3. Air regulation

Air regulation is done on the stove door.

The air regulator on the stove door provides ignition and fuel combustion.

Pay attention that the ash box is not overfull. Its emptying should be regular in order to provide unobstructed air intake.

The secondary air intake is on the stove door. The secondary air supplies fire with the oxygen needed for clean combustion (burning of previous incomplete combustion products). Due to poor oxygen intake, a great emission of harmful substances occurs, which can lead to blockage of the flue.

### 3.1. Primary air

Reliable fuel combustion is determined based on the primary combustion air. This air is adjusted by regulating the primary air on the oven door in the ashtray part (Figure 3, position 7). The air regulation on the oven door in the part of the ash space shows the direction of closing and opening of the regulator. To ignite the wood, the regulator should be maximally open. For optimal operation of the furnace, the required opening on the regulator is 15 mm.

**NOTE:** To prevent the stove overheating, fuel quantity must not exceed 1,8 kg of dry wood logs per hour, if the combustion air is properly adjusted.



Fig.3

### 3.2. Use of knobs on firebox door

As the knobs on the firebox door become very hot during stove combustion, closing and opening of the firebox door is possible only with a special wrench from the enclosed stove accessories (see figure 4).



Fig.4

## 4. Stove installation

During stove installation you should follow valid regulations regarding the construction and firefighting requirements. The placement site should be horizontal and with sufficient bearing capacity, otherwise the appropriate measures must be applied for equal load distribution. In case of flammable floor (wood, plastics, textile...) it is necessary to put steel-sheet, copper or other inflammable material on the floor beneath the stove. Such base must cover the stove profile for at least 30 cm, and on the operation side it should be greater in length by 50 cm.

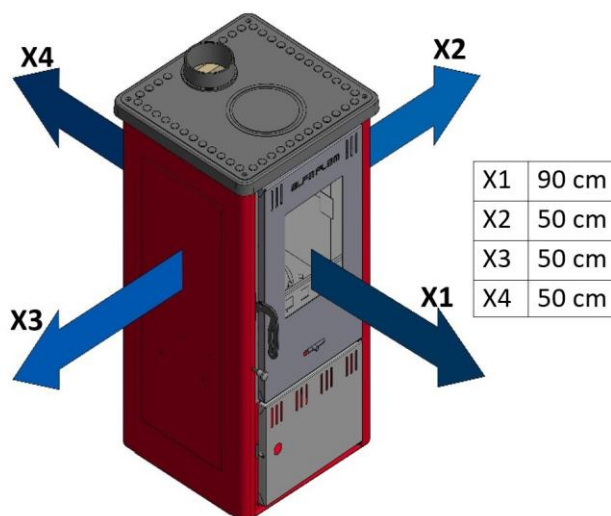

Fig.5

There should be enough space between the stove and flammable objects (with wooden sheeting, furniture, curtains etc.). The distance between the wooden parts of furniture or plastics and other flammable objects to be protected must be at least 50 cm to the sides and 50 cm on the back (Figure 5). There should be a distance of 90 cm at least between flammable objects from the stove filling opening.

Installation of objects above the stove is forbidden if the cast panel is used.

During the installation of used air drain pipe it is necessary to secure the distance of at least 50 cm away from flammable materials.

Before the stove is connected to the chimney it is mandatory to consult the local competent chimney sweeping organization. The flue-stove connection is done through the connecting elements according to SRPS.M.R4.031 (DIN 1298 or DIN EN 1856-2). Make sure that the chimney fittings do not protrude from the cross-section into the waste gas drain pipe, as well as that they have proper sealing function.

To achieve the best stove operation, the installation should be performed properly and perfect chimney should be provided. In any case it is necessary to inspect the existing flue pressure before the commissioning through the placement of lighted candle beneath the flue inlet. Chimney draught is considered sufficient if the flame bends towards the flue inlet. Slight flame bending indicates insufficient draught. The area where the appliance is installed should have satisfactory fresh air supply (Figure 6).

If two fireboxes are installed on a single chimney within a single floor (multiple engagement), the distance between the connections must not be less than 50 cm.

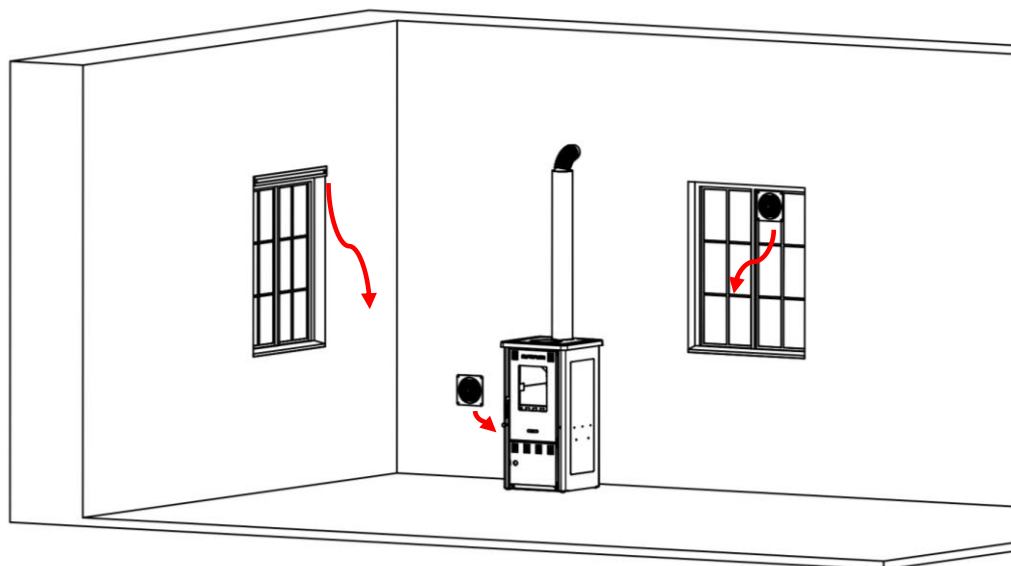

Fig.6

## 5. Stove commissioning

Before the stove is stoked for the first time it is necessary to wipe the enameled surfaces with damp cloth to prevent the formation of stains. Painted surfaces should not be touched and no objects should be placed on the stove, so that the paint would not get damaged. Finally, the paint hardens only after several hours of heating.

After reading the operation manual, the stove is commissioned for the first time. During the first stoking you should open the windows because the anticorrosive protection produces unpleasant smell and smoke. That is normal phenomenon, but soon ends. If necessary, turn on the fan for faster air circulation. Stoke up to the maximum temperature load, 1 hour at least. If the maximum temperature is not reached during the first stoking, problems with unpleasant smell might occur later also.

Sensitive persons such as pregnant women and children should be outside the room during this phase. Some built-in parts (drain pipe, ashpan door, stove door) become hot during operation, posing a risk of burns. Handrail on the firebox door becomes very hot during the operation, therefore the opening and closing of the door could be done only with protective gloves (see figure 7).

Keep children away from the stove. When the stove is stoked for the first time, small quantities of fuel should be stoked three times to prevent the formation of cracks on the firesand.

### 5.1. Stove commissioning and stove operation

- Open the primary air control damper to the maximum,
- Open the stove door,
- Insert soft wood shavings, chipboard or paper,
- Place two pieces of wood across,
- Ignite the paper,,
- Let the wood burn

After creating the grill, put new fuel and adjust the air regulator so that it is open 15 mm.. Never feed new fuel to flame!

#### ATTENTION

During the stove operation and wood logs are to be placed inside, the door should have two-phase opening mechanism: first, the door should be open slowly and partially (up to 3 cm), so smoke could be sucked into the chimney, and then the door could be fully open, but slowly to prevent ember fallout. At sudden opening, the stove door initiates the movement of certain amount of smoke. **If adding fuel, the door should be opened carefully to eliminate smoke. This method stops smoke from entering the room.**

Nominal heat output is achieved with the following fuel quantities and the primary air control damper settings.

Fuel type	Fuel quantity	Combustion time	Air control on the stove door near the ashpan
	kg	h	Degree
wood logs	1,8	1	15 cm open

The stove may be stoked only with natural wood logs. Wood logs are placed in pieces whose length measures 32 cm. Remember, this stove is not an appliance used for waste incineration.

While the stove is in function, the door has to be closed. Slightly above the door there are openings used for cleaning glass, with their function to enable the air supply inside the stove.

Lacquered, painted, veneered and impregnated firewood or wood treated with glue should not be used for the stove. In this case any manufacturer's warranty and liability become void. Firewood should be used dry (humidity up to 20%). As a rule, wood becomes dry after being stored in dry and well-ventilated place for two years. Wet wood has low calorific value and forms sediments inside the flue pipes, as well as the chimney.

Under the most adverse weather conditions certain hindrances could occur in the chimney (eg. poor weather conditions). In such cases the stove operation is not allowed for safety reasons.

### 5.2. Stove maintenance and cleaning

The stove should be inspected regularly by an expert. The stove, flue pipe and chimney should be cleaned regularly several times a year, at least once in the heating season.

Regular maintenance and cleaning are important for proper and reliable stove operation. Maintenance of enameled or painted surfaces is recommended only when the stove has cooled down. The stove should be cleaned with clean water and a soft cloth. Painted surfaces are cleaned with dusting brush or a dry cloth. Do not use water or damp cloths for cleaning painted stoves. The cleaning frequency depends on the type of fuel, namely the stove service life and the operation method.



Figure 7

The ashpan (figure 7) should be regularly emptied before each stove operation. The grate should be cleaned 1-2 times weekly. In case of clogged air inlet with slag or other combustion residues, these should be immediately eliminated and the grate should be

cleaned thoroughly. When it comes to stoking, soot formation should be avoided. Soot is produced during the combustion for the following reasons:

- Poor draught in the chimney (poor-quality chimney)
- The stove is handled improperly, eg. oxygen supply is interrupted too early. We do not have any influence on the above mentioned facts. Therefore, we cannot assume any responsibility for clean glass.

Glass on the door should be cleaned only if the stove has cooled down, with a cloth or newspaper soaked and dipped into ashes; the contaminated parts should be wiped down until they are clean completely. Regular detergents can also be used. While the stove is in function, the glass should not be cleaned for safety reasons! Under normal conditions the glass becomes dark in the ignition phase; however the color disappears during the use.

#### **ATTENTION**

The ceramic glass is resistant to high temperatures, but it could break due to thermal shock or heavy blow, therefore the glass should not be punched.

Cracks seen on the metal-sheet surface are created under normal thermal expansion during regular operation. These cracks do not compromise the work of the stove at all.

For optimal operation of the stove the following actions are necessary:

- Occasional and comprehensive cleaning,
- Occasional cleaning of the flue pipe to eliminate smoke and possible residue,
- Occasional cleaning of flue gas compartments (from firebox through the flue pipe),
- Empty the ashpan on the bottom of stove and remove all ash residue,
- Clean the chimney once a year to prevent sediment formation, otherwise in high temperatures such sediments could ignite, with severe consequences to the chimney and the entire house caused by improper behavior.



Figure 8

Shaking of the grate is performed via the knobs presented on figure 5.

## **6. General data**

If you adhere to the instructions for installing and use of the stove, this stove will be a reliable source of heat. All problems with Your stove can be resolved by our service. In case of complaints regarding problems or mistakes about the functions, please contact our service. They will help You as well as for orders of spare parts.

## **7. Handling and transport information**

When the oven is moved, special care must be taken to keep the oven in balance, so sudden movements should be avoided.

Before any movement of the oven, check that the truck has a capacity greater than the weight of the oven to be lifted: the operator is responsible for lifting the load.

## **8. Frequently Asked Questions**

### The ignition problems:

- Open the primary air and if necessary, open the ashpan door slightly,
- Use well-dried wood logs,
- Check whether the flue pipes are well-connected,
- Check the draught in the chimney,
- Check whether the ashes and the combustion residue have clogged the exhaust pipes or the firebox grate.

### Glass gets dirty very quickly:

- Wet wood logs: use dry firewood (10-20% relative humidity),
- Check whether the ashes and the combustion residue have clogged the exhaust pipes or the grate,
- Inappropriate firewood,
- The stove does not have sufficient pull (see the connection and the chimney),
- Setting is not well-adjusted: if the secondary air inlet is closed, the glass gets dirty quickly,
- There is a condensate inside the combustion chamber.
- In the first few ignitions the formation of condensate is expected, as the materials covering the stove contain moist,



- Check whether the chimney size is too big and whether the flame reaches the chimney top.

## **9. The Nameplate**

The nameplate is attached to the back or the bottom of stove, containing serial number that should be listed for each order.